

MOD. 1600

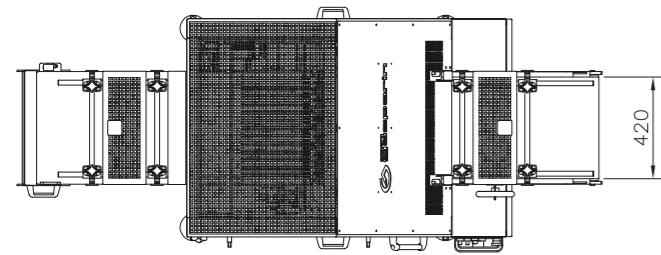
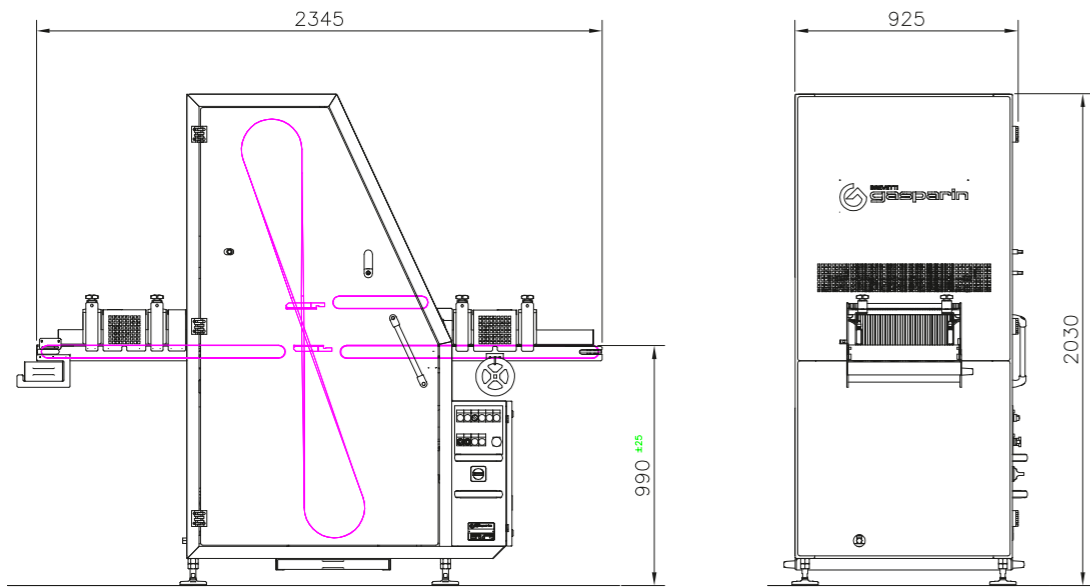

SLICING

MOD. 1600
CONTINUOUS BAND BLADES SLICER

TAGLIERINA A LAME CONTINUE
TRANCHEUSE À LAMES CONTINUES
CORTADORA DE CUCHILLAS CONTINUAS

All technical features and data are purely indicative and not binding. Gasparin reserves the right to modify its products without warning in any moment. - Le caratteristiche e le notizie tecniche sono indicative e non impegnative, la Ditta Gasparin si riserva di apportare modifiche in qualsiasi momento e senza alcun preavviso. - Les caractéristiques et les notices techniques sont fournies à titre indicatif et ne sont pas contraignantes. La société Gasparin se réserve le droit d'apporter toutes les modifications jugées utiles à tout moment et sans préavis aucun. - Las características y especificaciones técnicas son indicativas y no vinculantes. La firma Gasparin se reserva el derecho de aportar modificaciones en cualquier momento sin preaviso alguno.



BREVETTI GASPARIN SRL
Via 1° maggio, 19 | 36035 Marano Vicentino - Vicenza | Italy
T. +39 0445 560065 | F. +39 0445 622484 | info@gasparin.it

WWW.GASPARIN.COM



SLICING AND PACKAGING SYSTEMS FOR THE BAKING INDUSTRY
SISTEMI DI TAGLIO E CONFEZIONAMENTO PER L'INDUSTRIA DELLA PANIFICAZIONE E DOLCIARIA

MOD. 1600

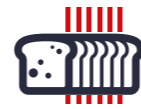

SLICING



EN

CONTINUOUS BAND BLADES SLICER

1. Suitable for the bread slicing at medium speed.
2. Cutting head with continuous blades mounted on two rollers rectified and balanced for a perfect adherence on the surface.
3. Blade guides fingers made in hard metal covered with Widia.
4. Blade pitch on request and interchangeable, minimum of 8 mm.
5. Entry loading conveyors: upper, with adjustable height, suitable to push the bread towards the blades and lower with adjustable lateral guides.
6. Adjustable Conveyors advancement speed through inverter.
7. Electric panel with centralized controls, emergency power according to regulations and protection plexiglass.
8. Heavy duty design in painted steel.

+ OPTIONAL

9. Pneumatic oiling system on blades.
10. Stainless steel version

IT

TAGLIERINA A LAME CONTINUE

1. Atta al taglio di pane a medie velocità.
2. Testata di taglio a lame continue montate su rulli rettificati e bilanciati per un'ottima aderenza.
3. Martelletti guida lame in metallo duro con riporto in Widia.
4. Passo lame a scelta ed intercambiabile, minimo 8 mm.
5. Nastri di carico in entrata: superiore, con altezza regolabile, atto a spingere il pane verso le lame ed inferiore con spondine di guida registrabili.
6. Velocità di avanzamento nastri regolabile tramite inverter.
7. Pannello elettrico con comandi centralizzati, emergenze elettriche secondo normative e plexiglass di protezione.
8. Struttura portante in robusto acciaio verniciato.

+ OPTIONAL

9. Oliatura pneumatica lame.
10. Versione inox.

FR

TRANCHEUSE À LAMES CONTINUES

1. Prévues pour trancher le pain à vitesse moyenne.
2. Tête de coupe à lames continues montées sur des rouleaux rectifiés et équilibrés pour une adhérence parfaite.
3. Crochets guide-lame en métal dur avec report de widia.
4. Pas des lames réglable et interchangeable, minimum 8 mm.
5. Tapis de chargement en entrée : supérieur, avec hauteur réglable, conçu pour pousser le pain vers les lames et inférieur avec guides latéraux réglables.
6. Vitesse d'avancement des tapis réglable par variateur.
7. Tableau électrique avec commandes centralisées, alimentation de secours conformément à la réglementation et protection en plexiglas.
8. Structure porteuse robuste en acier peint.

+ EN OPTION

9. Huilage pneumatique des lames.
10. Version inox.

ES

CORTADORA DE CUCHILLAS CONTINUAS

1. Apta para el corte de pan a velocidad media.
2. Cabezal de corte de cuchillas continuas montadas en rodillos rectificadas y equilibradas para garantizar su perfecta adherencia.
3. Ganchos de guía de las cuchillas de metal duro con refuerzo de widia.
4. Paso de las cuchillas intercambiable, mínimo 8 mm.
5. Cintas de carga de entrada: superior, de altura regulable, apta para empujar el pan hacia las cuchillas, e inferior con guías laterales regulables.
6. Velocidad de avance de las cintas regulable con inverter.
7. Panel eléctrico con mandos centralizados, emergencias eléctricas según la normativa y plexiglás de protección.
8. Estructura portante de sólido acero pintado.

+ OPTIONAL

9. Lubricación neumática de las cuchillas.
10. Versión inoxidable.

MAX. PRODUCT LENGTH	LUNGHEZZA MAX PRODOTTO	LONGUEUR MAX PRODUIT	LONGITUD MÁX. PRODUCTO	400 mm
MAX. PRODUCT HEIGHT	ALTEZZA MAX PRODOTTO	HAUTEUR MAX PRODUIT	ALTURA MÁX. PRODUCTO	130 - 150 mm
PRODUCTION	PRODUZIONE	PRODUCTION	PRODUCCIÓN	16 - 40 pcs/min.
POWER	POTENZA	PUISSANCE	POTENCIA	5,5 kW
WEIGHT	PESO	POIDS	PESO	900 Kg

